

: 90%

, 60...70%

150

170

«

» -

.1

, A.C. SU 1041492.

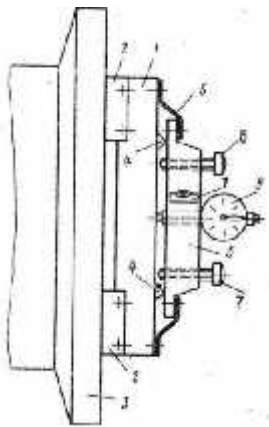

.1.

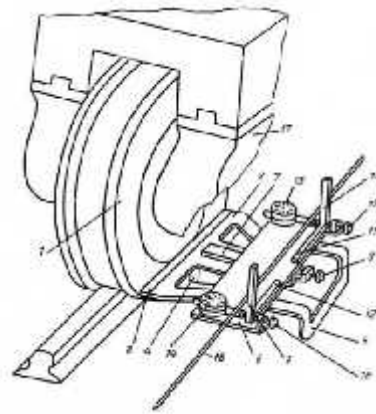

.2.

8,

1

2

7,

3

3.

5,

9,

SU 1244076

SU 1837047, .3.

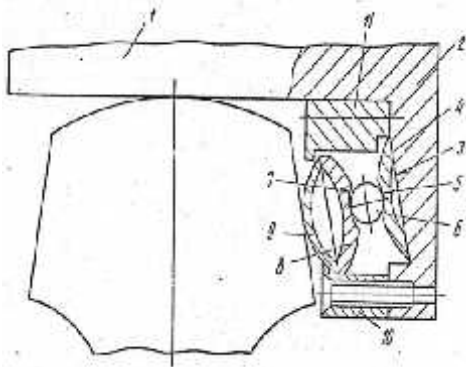

.3.

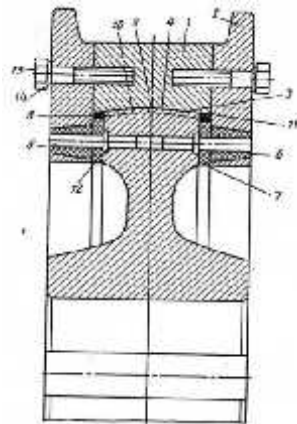

.4.

9
 4,8 9
 5 7
 6
 4 8.
 . . . SU 1289800, .4,

621. 23

