

620.179

_____ . ,

• , • •

,
.

$$d = 5 \cdot 10^{-4}$$

$$L = 1,393 \cdot 10^{-3}$$

$$D = 1,3 \cdot 10^{-2}$$

$$W = 20,$$

$$R = 0,833$$

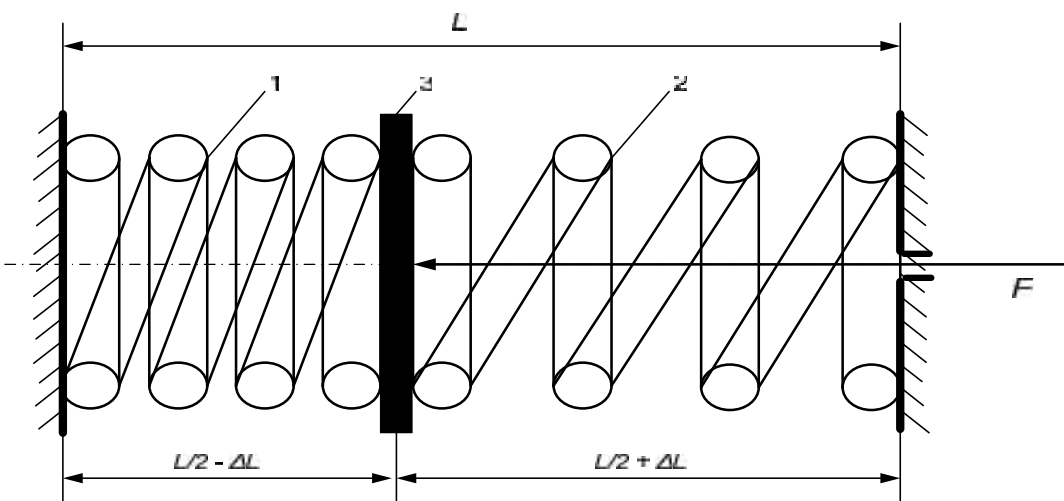

1 – F –

F; 2 – F; 3 –

2
). 1 2
 (F = 0), 10 ,
 F = 0, 2 , 4·10⁵ / .

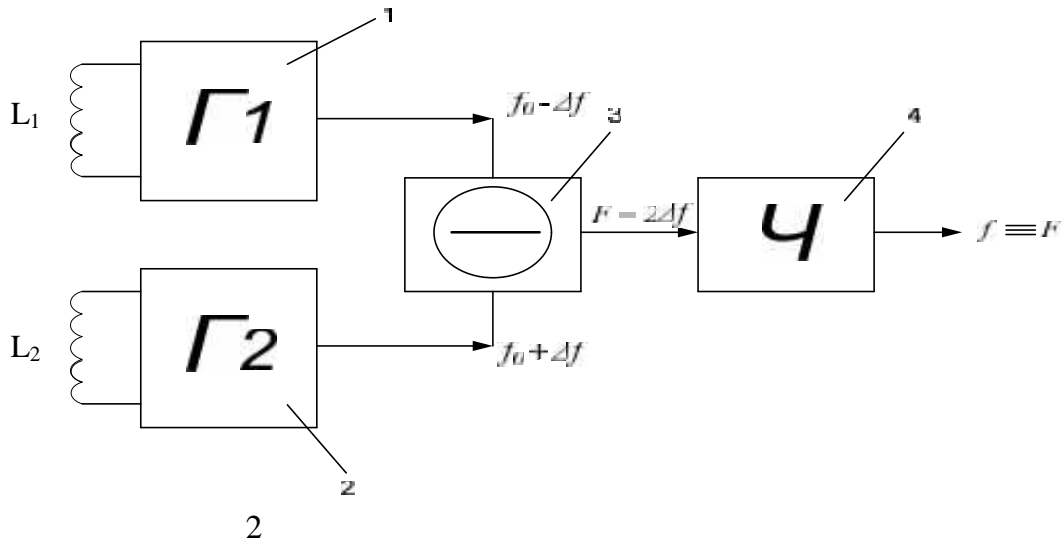

62-83:621.313.333

SIMMECHANICS