

5.

—

$$N_{i,min}(t) \quad N_{i,max}(t).$$

-5,

. .

$$=-15^\circ \quad 0^\circ .$$

621.31

_____

●		;	-
●		;	-
●		-	-
	;		-
●	;		-
●		,	-
;			-
●	;		-
		,	-
		;	-

- 2 .

- 2 .

- 2 .

- 1 .

. 1 .

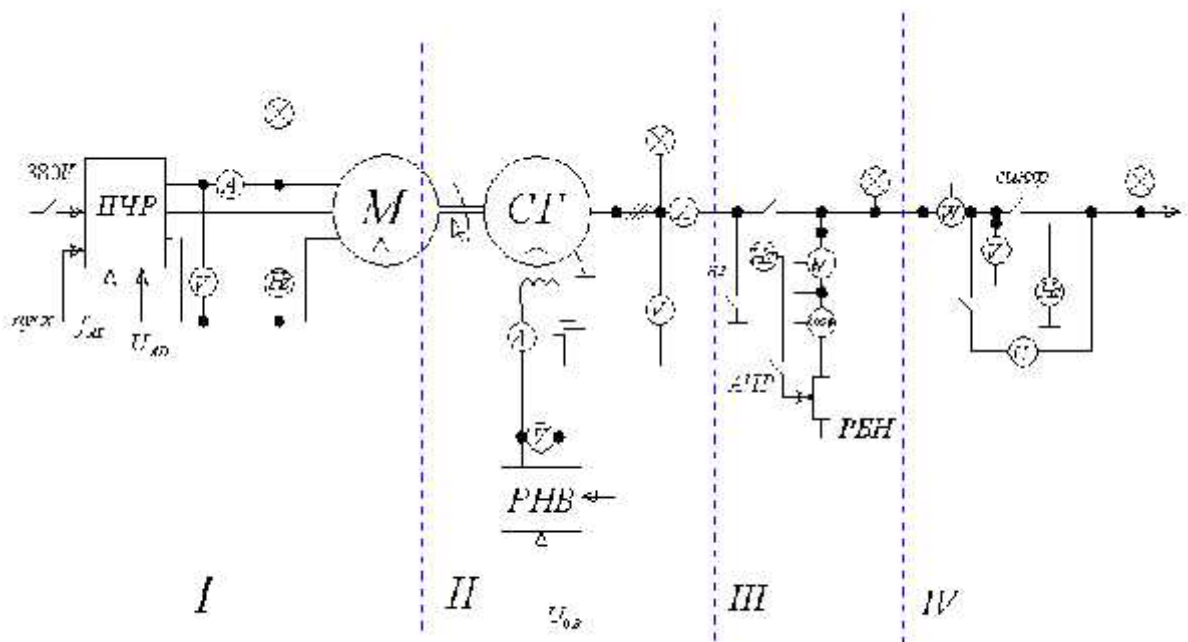

. 1

; - ; - - ; -
 ; - ; -
 U = 180 ÷ 230V 50 60
 ; - ; -
 . 327;
 . 4 : , , , -
 1 -
 , . 2 - -
 . 3 - . 4 -
 ,
 , . - -
 , ,

: 1.

2. Journal of marine science and technology, vol.14, No.2, pp. 84-96. A damping constant limitation designed of power system stabilizer using hybrid differential voltage. Yung-Sung Chuang, Chi-Jui Wu.

621.311.22

_____