

2
). 1 2
 (F = 0), 10 ,
 F = 0, 2 , 4·10⁵ / .

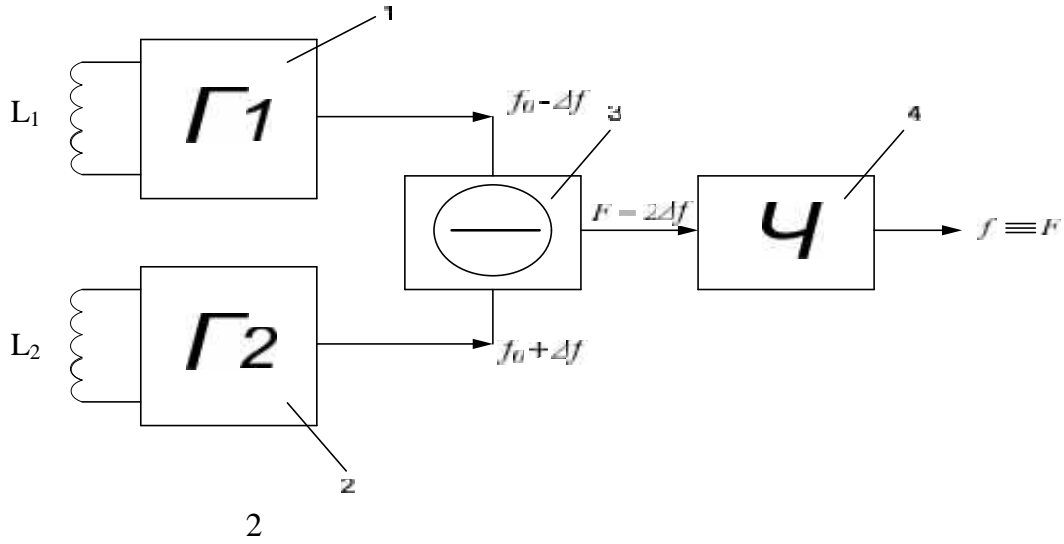

62-83:621.313.333

SIMMECHANICS

SimMechanics,

Simulink-

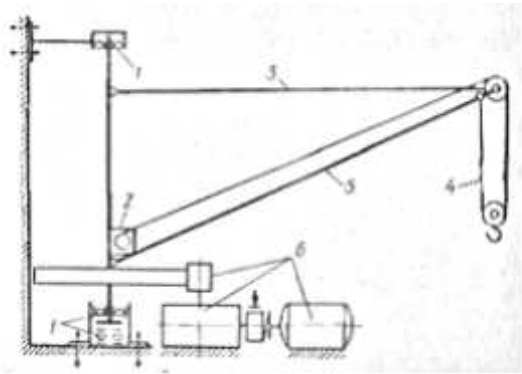

(.1)

4

5

- 6.

- 2,

1,

-

3,

-

.1

Matlab

SimMechanics

Simulink SimMechanics,

: 1.

: - .: - , 1980.-360 ., . 2. . . Simulink 5/6/7:
 . - .: - , 2008. - 784 .: . 3. - . . Matlab & Simulink.
 . - .: - , 2008. - 368 .