

V.I. Gurevich

STABILITY OF MICROPROCESSOR RELAY PROTECTION AND AUTOMATION SYSTEMS AGAINST INTENTIONAL DESTRUCTIVE ELECTROMAGNETIC IMPACTS PART 2

В статье рассматриваются проблемы воздействия мощных электромагнитных импульсов, генерируемых при ядерном взрыве или с помощью специального оборудования, предназначенных специально для повреждения электронной аппаратуры, в частности микропроцессорных устройств релейной защиты и автоматики, а также меры защиты от этих воздействий.

Problems of impact of the electromagnetic high-power pulses generated at nuclear explosion or by means of the special equipment, intended specially for damage of the electronic equipment, in particular digital protective relays and automatic systems, and also ways of protection from these impacts are considered.

3. EXPOSURE OF MICROPROCESSOR-BASED RELAY PROTECTION DEVICES TO INTENTIONAL DESTRUCTIVE ELECTROMAGNETIC IMPACTS

Various antenna arrangements, cable terminals, power-supply system, currents induced in encasement and emissions penetrating through windows and doors made of non-conductive materials and air ducts are the primary routes for penetration of EMP into the electronics. Currents induced by EMP in land and buried electric cables extending for hundreds and thousands of kilometers may reach thousands amperes and the voltage in open circuits may reach millions of volts. Antenna leads with the length of only several meters may have induced EMP currents of several hundreds amperes. EMP penetrating through construction elements made of dielectric materials (non-shielded walls, windows, doors, etc.) may induce currents of dozens of amperes in the interior wiring. Long overhead power transmission lines absorbing emission from large areas and delivering it directly to the inputs of high-sensitivity electronics are particularly vulnerable. Transformers which can be installed in this way (metering and power) have little effect on this process due to significant internal capacitance between primary and secondary windings. Since low amperage circuits and radio-electronic devices normally operate under very low voltages and currents (up to several volts and several dozens of milliamps) the amperage and voltage at the inputs must be lowered by several digits in order to ensure reliable protection against EMP. Amazingly, optical data transmission systems, widely used in relay protection, are as sensitive to EMP as MPDs. This refers to controllers converting electrical signals to optical at one end of a fiber-optical communication line (FOCL) and restoring them from optical signals at the other end of FOCL. For example, IEC standard compliance tests of electromagnetic compatibility of multiplexer types FOCUS [35] showed that this equipment is susceptible to faults and damage even under standard influences. The SCADA system with a high number of microprocessor detectors and initial elements connected into computer network is also exposed even to low EMP.

While the risk of high-altitude nuclear explosions as sources of EMP aimed at destroying national power sys-

tem is hypothetical, the probability of using non-nuclear EMP generators by terrorists to simultaneously destroy the most important nodes of the local electric power systems is rather high at any moment.

Data transfer systems using broad-band protocols are the most vulnerable to intentional electromagnetic pulses (ATM 155, Fast Ethernet, Gigabit Ethernet, etc.). This can be explained by insignificant differences between the power of the desired signal and the power of the interference in the upper spectrum. Today, coaxial cables are substituted with simple twisted-pair cables in order to make cabling cheaper, but it makes the system even more vulnerable. Even today, twisted-pair Ethernet cables are used in relay protection and, according to Smart Grid concept, this trend will be extended to all power industry controls.

Discrete electronic elements are much more impervious to voltage surge and other harmful effects than chips [36]. According to [37] 75 % out of all damages to microprocessor devices result from voltage surge. Such voltage surges with an amplitude from dozens of volts to several kilovolts generated as the result of circuit switching or under the electrostatic discharges are "lethal" for internal microelements of chips and processors. According to [37] regular transistors (discrete element) can withstand up to 70 times higher voltages of electrostatic discharges than memory chips (EPROM) of microprocessor systems. Computerized industrial equipment (including, but not limited to, MPD) is especially exposed to EMP as it is generally built on high-density MOS-devices, which are very sensitive to high-voltage transition processes. The specific feature of MOS-device is very low energy (several tens of volts) needed to partially or totally destroy it.

There are three levels of semiconductor device degradation under the powerful EMP: functional disorder, persistent parameter change and catastrophic irreversible failures. Irreversible failure of a semiconductor is mainly caused by overheating or field breakdown. [38-40]. Damages to microchip or memory elements resulting from tapped electromagnetic impact can be hidden [15]. Such damages can't be discovered by any tests and can appear unexpectedly. Besides, such EMP tapped by protection can cause random reversible failures resulting from spon-

taneous changes of the memory element content: "soft-failures" or "soft errors". Errors of this kind (reversible and self-recovering malfunctions) were not previously detected on electronics built on discrete semiconductor elements or regular chips.

Recent developments in nanotechnologies have significantly decreased the size of semiconductor elements (units and fractions of micron), reduced thickness of semiconducting and isolating materials, lowered actuating voltage, increased operating speed, reduced electric capacity of individual memory cells and increased packing density of elemental logic cells in the device. All this has resulted in the sharp increase in the vulnerability of memory elements to electromagnetic pulses. The problem is exacerbated by the steady trend of memory element expansion in the up-to-date microprocessor structures. Many modern high-integrated chips of microprocessor devices contain a rather large number of integral memory elements with totally uncontrolled working order. A sharp increase in vulnerability to EMP is also observed in high-speed logical elements, comparators, etc., that is in almost all modern microelectronics.

The Faraday cage is known as a good protection measure against EMP. Concrete-steel constructions containing a grounded grid and protection relays are located in metal cabinets and MPD are enclosed in metal cases: not so much of a cage rather a Faraday "matryoshka" (a matryoshka doll is a Russian nesting doll which is a set of dolls of decreasing sizes placed one inside the other). However, there is more than meets the eye. First of all, high-frequency pulses freely penetrate the gaps in the Faraday cage through any non-metallic inserts and openings, glass windows and air ducts. Such partially attenuated EMP effects can cause partial destruction of *p-n*-transitions of semiconductor devices resulting in changes of the parameters and "flickering" failures of the apparatus. Such failures require a lot of maintenance resources and limit the certainty in the apparatus reliability. "Flickering" failures sometimes are difficult to detect which require repeated disablement of equipment with significant operating time spent on damage diagnosis. This factor should also be considered in estimating the protection of apparatus against electromagnetic attack as partial or incomplete protection can cause additional problems.

Another known problem, the so called "delayed EMP effect", is an extremely dangerous HEMP property. This effect appears within the first minutes after a nuclear or electromagnetic detonation. At this time, EMP penetrating into electric systems generates localized electromagnetic fields. During the attenuation of the fields, there are sharp voltage changes that appear which propagate in the form of waves over long distances from the source of the initial EMP through the power lines. Thirdly, mile-long external outbound cables and wires of the RP cabinet and building deprive even the attenuation effect of RP cabinets and building.

4. PROTECTION OF MPD AGAINST EMP: PROBABLE LINES OF ATTACK ON THE PROBLEM

Ideal protection against EMP would be the full isolation of electronics against the environment and covering the building with a bulk thick-walled ferromagnetic

shield. At the same time, we must realize that, in practice, such MPD protection is impossible.

Thus, in practice we have to use less reliable protection measures, such as conducting grids or conducting coating films for windows, honeycomb metal structures of air intake and air holes as well as special conductive lubrication and conductive rubber gaskets located on the frames of doors and hatches.



Fig. 8. Control cabinet with upgraded protection against EMP equipped with special loops, conductive rubber gasket, special coupling and connecting elements, shielded air vent windows, etc. (Equipto Electronics Corp.)

Today, there are special metal cabinets available on the market that ensure significant attenuation of EMP. Standard cabinets made of iron sheets having no windows or gaps provide significant attenuation of EMP. Galvanized assembling panels of such cabinets, as well as special conductive seals, significantly increase the effectiveness of such cabinets since galvanizing allow equalizing potentials within large areas (steel specific resistance is 0.103-0.204 Ohm x mm²/m, and zinc specific resistance is 0.053-0.062 Ohm x mm²/m). Aluminum has even lower resistance (0.028 Ohm x mm²/m). Thus some manufacturers produce single-block cabinets from a special alloy: ALUZINC150 (Aluzinc® - registered trademark of Arcelor) – the material of which is 55 % is covered with aluminum, 43.4 % with zinc and 1.6 % with silicon. The surface of the cabinet with this covering provides a high deflection of EMP. These Cabinets are manufactured and supplied to many countries by the Sarel company (today - Schneider Electric Ltd., Great Britain). Similar cabinets providing protection against EMP are also manufactured by other companies, such as Canovate Group, R.F. Installations, Inc.; Universal Shielding Corp.; Eldon; Equipto Electronics Corp.; ATOS; MFB; European EMC Products Ltd; Amco Engineering; Addison, etc. This equipment usually attenuates the emission per 80-90 dB on a frequency of 100 kHz – 1 GHz.

Certainly, control cables must be shielded with twisted-pair. The minimum requirement to the shield is high density of armor (not less than 85 %).

Double-shielded cables have much a better shielding effect, see Fig. 9. For relatively low frequencies (up to several tens of MHz) the braided screen provides better shielding than the foil mainly due to its thickness.



Fig. 9. Double shielded cable. Left – with double braided screen; right – with double combined shield (braided screen and foil)

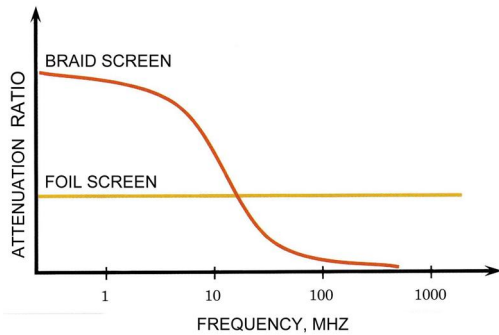

Fig. 10. Dependence of shield factor from frequency for braid-foil shields

However, the shielding properties of the braided screen sharply decrease and become almost unacceptable before the frequency reaches 100 MHz. At the same time, the foil has flat AFR maintaining acceptable shielding properties over a wide range of frequencies up to the GHz range, see Fig. 10. Thus, cables with combined braided-foil shield are the most preferable. Excellent protection against EMP use cables combining pair-twisted wires, foil shields for each pair of wires and three-layer common shield made of foil, see Fig. 11.



Fig. 11. Cable RE-2X(ST)2Y(Z)Y PIMF characterized as interference superstable (transmitting analogue and digital signals up to 200 kbit/sec; pair-twisted wires, each pair shielded with PE foil; three-layer common foil shield armored with steel wire; external XLPE isolation; up to 24 pairs of wires per cable; can be used outdoors and for burial; has high mechanical strength)

The Belden Company has developed and patented a simple and effective method for shielding cables based on foil-coated PE film (poly-sandwich) under the name of Beldfoil®. The company produces cables with two layers of foil and braid, or even four layers, where foil interstratifies with braid two times combining best properties of foil and braid in one cable, see Fig. 12.



Fig. 12. Multilayered shielding of poly-sandwich developed by Belden

The effectiveness of cable shielding depends heavily on the grounding effectiveness. As shown in [42], on the one hand the grounding of control cable shield is effective only against capacitive pickups (referred to as: electrostatic protection) and doesn't protect against inductive pickups (interference reduction factor $k = 1$) since the shield doesn't provide a chain for closing the interference current.

If the shield is two-side grounded, there is an additional chain (shield) with much lower impedance for high-frequency signals than the ground. As a result the operating signal is divided into two components: low-frequency component goes through the ground and high-frequency goes through cable shield. Therefore, for the high frequency component the current in the shield is equal to the current in central core directed in the opposite direction and is compensated due to inductive coupling between shield and central core. This provides protection against high-frequency pulses emitted from the central core to the environment (to adjacent cables) with an interference reduction factor $k = 3-20$. This system is also effective under an external electromagnetic pulse to the shield when the high-frequency signal induced into the shield is bridged through the ground. When connecting the shield to the ground bus, it should be considered that a "wrapping" connecting wire on the shield is unacceptable as well as coiling a long connecting wire between shield and ground bus. Each additional loop increases the impedance of the grounding on high frequencies and significantly reduces its effectiveness. For cabling at substations, laying a two-side grounded potential-equalizing copper bus in parallel to the cable run can be an additional solution capable of improving efficiency of the shield. Its effect is provided by the fact that copper bus impedance on high frequencies is much less than ground impedance (and even shield impedance), so the main component of the pulse interference high-frequency current will run through the bus rather than through the shield.

While new cables with multilayered foil shielding are capable of effectively attenuating external EMPs, old types of cables with sparse braid do not satisfy these needs. In order to attenuate an external electromagnetic field these old cables can be laid in metal trays and tubes. Plastic metalized trays widely used for laying control cables have the least shielding effect.

Due to a very thin conductive layer such a structure operates effectively only on frequencies of 600 MHz and above. On frequencies under 200 MHz it doesn't work at all [42]. At the same time, aluminum trays combined with copper cable braid can attenuate induced voltages tenfold, thus they can be widely used as effective EMP protection measure. However, laying cables in steel water pipes ensure the best attenuation of induction over a wide range of frequencies.

Prevention of EMP penetration into the apparatus through different cable entries and connections (plugs) is a more difficult technical problem than cable shielding.

Today, there are a lot of special connectors with integrated EMP filters available on the market, see Fig. 13, from many manufacturers, such as Amphenol; Spectrum Control Inc., Spectrum Advanced Specialty Products; EMP Connectors; ERNI Electronics; Sabritec; MPE; Glenair Inc.; Captor Corp.; Lindgren-Rayproof, etc.

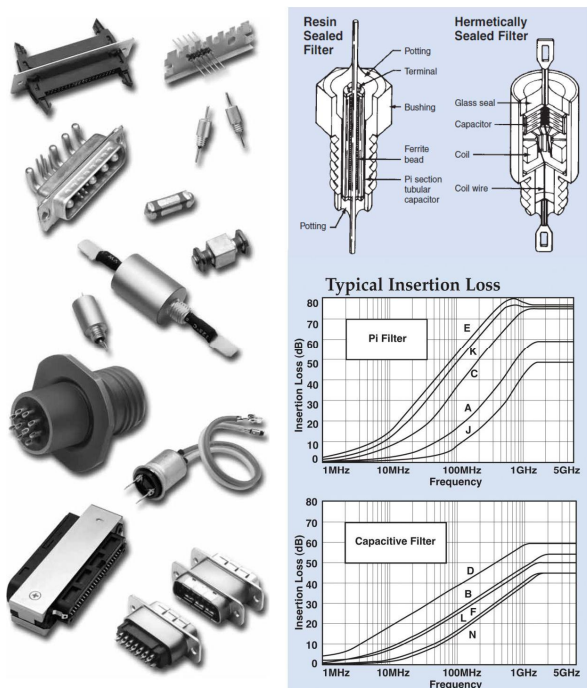

Fig. 13. Several types of input connectors with integrated filters manufactured by Spectrum Control Inc.

As a rule, such filters are manufactured based on ferrite rings or combined inductances and capacitances, see Fig. 14, installed into the connector, see Fig. 15.

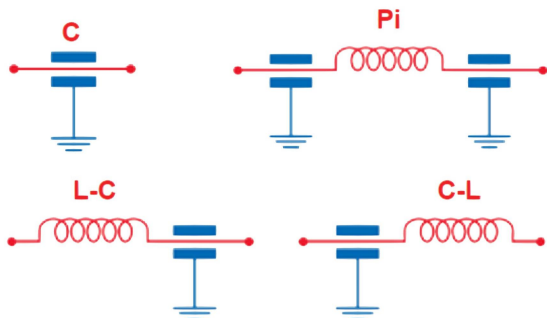

Fig. 14. Typical circuits of filters integrated into connectors

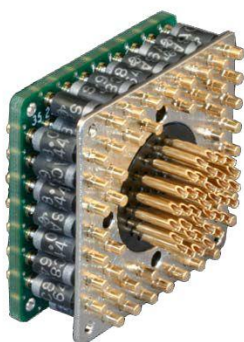

Fig. 15. Design of a connector with integrated filters by Glenair Inc. High number of filtering elements are installed between two plates

Filters, spark arresters, metal-oxide varistors and Zener diode HS suppressants are widely used for protection of cable entries. The whole range of such devices is produced by Company RFI Corporation and others, see Fig. 16.

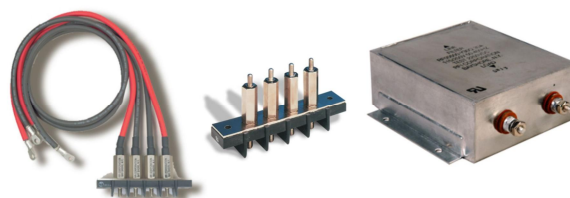

Fig. 16. Cable entries filters manufactured by RFI Corporation

The range of filters manufactured by this company includes filters for high currents (0.01 to 5000A) and voltages (12 VDC to 5500 VAC).

Some manufacturers also produce power filters with wide frequency characteristics which are especially designed for protection against HEMP. Filters of the Captor Corp. demonstrate excellent characteristics, see Fig. 17, and EPCOS power filters, see Fig. 18, in the range of operating currents up to 150 A (surge currents up to 12 kA) and a voltage of 440V. In such filters under the operating currents the voltage drop reaches < 1 % per phase and attenuation reaches 100 dB over a frequency range of 14kHz-40GHz. EPCOS also manufactures cabinet-type, three-phase filters working under the same frequency characteristics and operating currents of 1600 A, as well as low power multi-channel filters for actuating and control circuits.

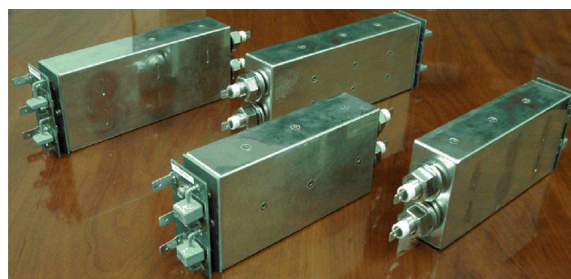

Fig. 17. Sealed power filters manufactured by Captor Corp. designed for AC and DC power circuits up to 100A ensuring effective EMP attenuation to not less than 100dB within the frequency range of 14kHz-10GHz

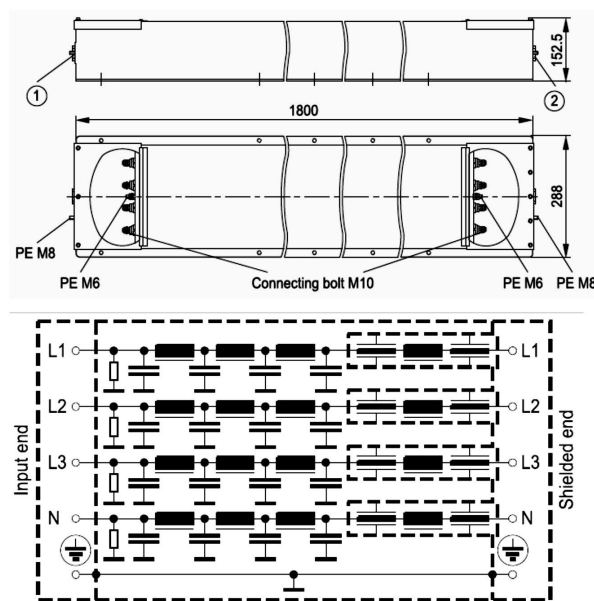

Fig. 18. Dimensions and circuit diagram of three-phase EPCOS filter (150 A, 440 V)

Many manufacturers offer excess-voltage suppressors based on zinc-oxide varistors designed for 220/380/660V circuits and allowing breakdown currents of up to 80kA. Often, such devices contain in series, short-circuit protection fuses protecting the circuit in case of varistor damage, and a blown-fuse indicator, see Fig. 18.



Fig. 19a. High-capacity protecting devices based on metal-oxide varistors designed by Square D (Schneider Electric)



Fig. 19b. Powerful varistors of different types with rated voltage of 130-1100 V and breakdown current of 3-100 kA

Metal-oxide varistors have high power but not enough performance for protection against HEMP. Their parameters decline under the repeated high-power impulse loads. High-speed silicon Zener diode excess-voltage suppressors do not have such disadvantages (Transient Voltage Suppressor Diodes or TVS Diodes). Their operation is based on a sharp drop of the resistance from relatively high value to almost zero under induced excessive voltage with a certain threshold, see Fig. 19.

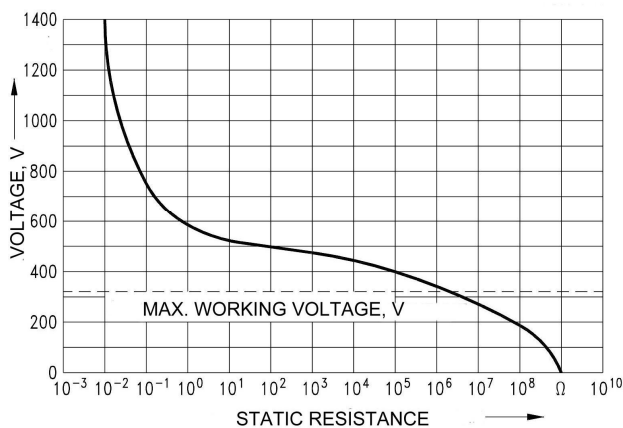

Fig. 19c. Typical volt-amps diagram of zinc-oxide varistors

Besides, contrary to varistors, the parameters of such excess-voltage suppressors do not decline under the repeated high-voltage effects and mode switch see Fig. 20.

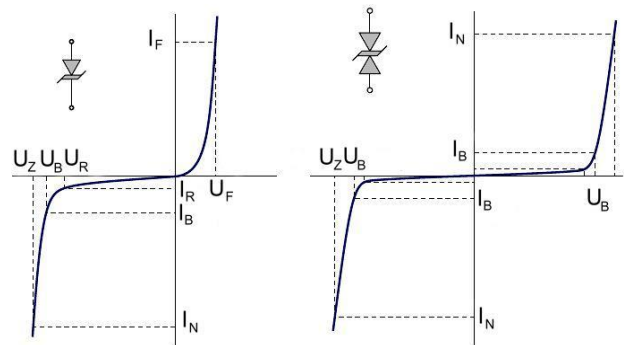

Fig. 20. Volt-amps diagram of mono-directional (DC) and bidirectional (AC) diode suppressors

Unfortunately, most modern suppressors of this type have limited pulse power (up to 1500W under voltages of up to 600V) and are suitable for protecting electronics inputs but not for power and supply circuits. However, several companies, such as Littelfuse, specialize in the development and production of elements protecting against surge voltage. Littelfuse, for example, manufactures suppressors of much higher impulse power up to 30 kW and discharge pulse currents up to several hundreds of amperes.

Varistors diode suppressors can be connected in-parallel in order to increase discharge current. In-parallel connection of different suppressors, such as varistors and semiconducting suppressors, enables improving efficiency of surge voltage protection, see Fig. 21. Such a hybrid device demonstrates excellent characteristics: initial reaction is provided by fast-response suppressor 1 responding to pulse with an even steep leading edge and absorbing a part of its energy; discharge current is limited with resistors 2 preventing damage to suppressor.

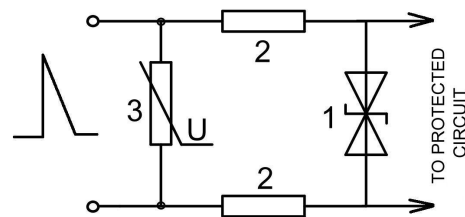

Fig. 21. Hybrid protection device: 1 – semiconducting suppressor; 2 – current-limiting resistor; 3 – powerful varistor

The voltage drop on resistors 2 increases the voltage on varistor 3 resulting in sharp decrease in its resistance and bridging resistors. The rest (the most part) of energy is absorbed with a powerful varistor.

While designing means to protect against intensive EMP, it should be considered that only one type of protection is not capable of ensuring effective overall protection. Thus, only the combination of all available protection means can provide complete protection.

One of such types of protection means is protection of buildings and premises against EMP. The most effective protection is ensured with special panels combining EMP-reflecting and absorbing layers, see Fig. 22.

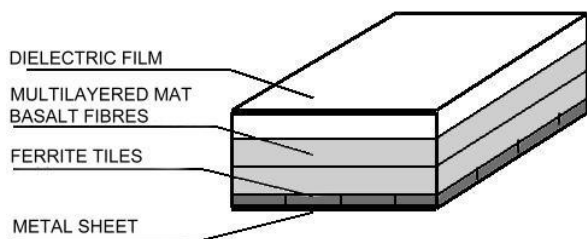

Fig. 22. Integrated protecting panel "Ferrilar-5"

However, fully shielded premises would cost a lot of money. Therefore, in practice cheaper intermediate options including protective paints, films, curtains, hangings, etc. can be used. Over recent years significant progress has been made in developing conductive paintings and construction materials with unique properties and wide application, as well as clear conductive coatings which can be applied on the glass. Conductive paints, lacquers and sprays based on copper, aluminum, brass, nickel and graphite are manufactured by many companies, such as Caswell, YSHIELD EMR-protection Company, Less EMF Inc, Gold Touch, Inc., Spraylat Corp., Cybershield, Applied Coating Technologies Ltd, BM Industria Bergamasca Mobili S.p.A. High results shows protecting paint Tikolak developed by Moscow company Tiko. Tikolak is a new patented (in Russia) universal non-metal conductive coating material combining carbon filling compound with polymeric binding agent (8-20 % epoxy plus graphite-soot compound with a mass ratio of 0.1:1.0:11-39 %, hardener 0.5-1.5 %, organic solvent, etc). According to Tiko, this coating ensures shielding against EMP over a wide frequency range up to 300 GHz. Interior and exterior surfaces of a building coated with Tikolak are characterized with manifestly less EMP penetrability. According to the manufacturer one layer of Tikolak (only 70 micron) is able to reduce EMP intensity by 3 – 3.5 times. This coating can be used on a variety of construction materials, such as chip board, wood, gypsum board, as well as with any flexible material, such as fabric, leather, film, paper, etc. This coating can be covered with any decorating material, such as wallpaper, paint, ceramic tile, etc. and it costs much less than any foreign analogues (about \$70 per 1 kilo).

In order to get clear conductive glass reflecting EMP the oxide films of such metals as tin, indium, zinc and others are used. Production of such glass is very complex and demanding while requiring costly equipment and qualified staff. Tiko has developed and patented (patent RF No.2112076) a high-tech and economic way of covering the glass with conductive coating based on indium and stannum oxides. Clear conductive glass is manufactured by many companies, such as Tycon Technoglass, Pilkington, Shenzhen Wanyelong Industry Co., Ltd, InkTec, etc.

The Alfapol Company in St. Petersburg has developed construction materials based on shungite, which is a composite of solid carbon materials representing, in general, amorphous carbons close to graphite. The chemical composition of shungite is unstable: on the average it contains 60-70 % of carbon and 30-40 % of soot. Soot contains 35-50 % of silicon oxide, 10-25 % of aluminum oxide, 4-6 % of potassium oxide, 1-5 % of sodium oxide,

1-4 % of titanium oxide and other compound materials. Shungite combines the properties of regular construction materials with rather high electrical conductivity. This determines the ability to shield EMP [43]. According to Alfapol, shungite composite radio shielding materials can be divided in two classes by shielding method:

- **Construction materials**, including concrete, bricks, brick mortar. These materials are capable of providing EMP energy attenuation at frequency ranges of more than 100MHz at a level of not less than 100dB. Their physical-mechanical characteristics match conventional construction materials. Shungite materials were tested in structures (concrete in slabs, bricks in blocking) and proved to be compliant with the current requirements.

- **Reconstruction materials**, such as plasters and pastes for converting conventional premises into shielded. Layer of pastes (2-3 cm thick) provides shielding at level of not less than 30dB at a range of more than 30MHz. Plaster composite "Alfapol SHT-1" provides attenuation of EMP per 10-15dB over a range of 10kHz-35GHz with the thickness of plaster layer of 15mm. Conductive curtains, fabric and floor coating of different manufacturers can be used in addition to shungite walls, see Fig. 23.



Fig. 23. Conductive films, fiber and fabric attenuating EMP (up to 80dB) manufactured by Koolon Fiber Tech. Corp.

4. IMPROVING DURABILITY OF MPD

In order to improve the durability of MPD both technical improvements and organizational arrangements are required, in our opinion.

Technical improvement is to equip each MPD with a separate module containing special EMP filters (ferrite rings, combination of different arresters, etc.). All ingoing and outgoing MPD circuits should go through this module. All manufacturers of MPD should be obliged to equip their units with such modules. Such a module effectively matches the current module structure of MPD [44], and it can be replaced within the whole MPD lifecycle if new protection technologies and filtering modules appear in the market. This concept particularly includes implementation of standards for modular MPD construction and manufacturing MPD as standard modular boards which can be combined in RP cabinets with improved EMP protection [44].

Today, Russian experts have investigated improving RP stability by implementation of two-level relay protection. B. D. Schedrikov proposes [45] effecting the first level of relay protection with MPD and the second level with a conventional electromechanical relay of type PT-40 plus a time relay of type PBM-12. Both sets of

relays (MPD and electromechanical relay) are connected in-parallel and the electromechanical relay actuation time exceeds MPD actuation time by 0.1 second. Schedrikov expects that that the electromechanical relay should spot for MPD in case of malfunction under emergency mode (in fact it operates under the logical OR function). It should be noted that the in-parallel connection of MPD and electromechanical relay is not something unknown and has been practiced for a long time, see Fig. 24 [46].



Fig. 24. Distance protection of lines based on MPD type MiCOM P437 (bottom) and on electromechanical type LZ-31 (top) connected in-parallel

However, such a connection scheme doesn't eliminate false responses of MPD under EMP, which can result in at least as serious power network problems as malfunction. In his next article Schedrikov proposes changing from an in-parallel connection of electromechanical relay and MPD to the scheme where the electromechanical relay of type KPB-126 permits actuation of a breaker trip coil through microprocessor relay (using the logical AND function). Surely, such actuation ensures improved relay protection stability to false responses at HPEM, but reduces total relay protection reliability (it is the inevitable consequence of improved sustainability to HPEM).

It is fair to say that we proposed to improve MPD sustainability to powerful EMI with electromechanical relay permitting MPD actuation in [47] 15 years before the proposal of two level relay protection was published and we suggested the idea about hybrid (mechanical-semiconductor) relay protection device almost 20 years ago [48]. Moreover, it was not an abstract idea, rather it was a real design [49-51]. Today, thanks to the advent of a new element base, such as miniature high-voltage reed switches, reed switches for large switched currents, small-sized transistors and thyristors with an operating voltage of 1200-1600V and switched currents of tens of amps, there are new opportunities for the creation of hybrid relay (as a stand-alone protecting relay, or as a starting unit for MPD).

In the publication [52], we attempted to demonstrate the schematic of modern hybrid relays. In the electromechanical part we recommended using reed switches.

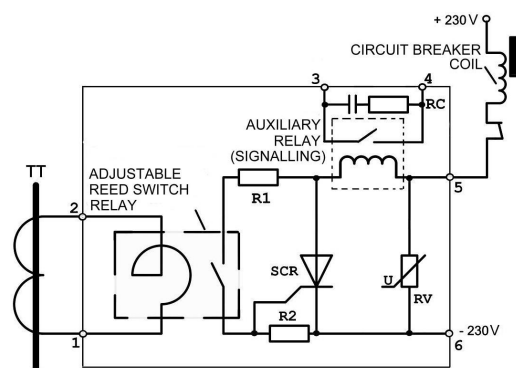
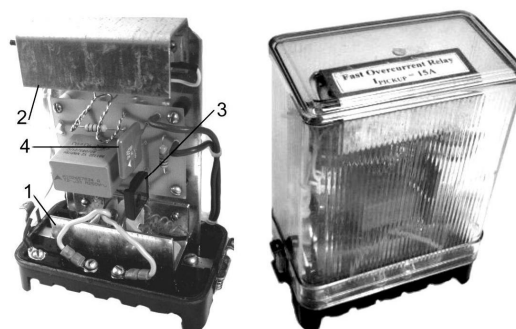

Fig. 25. Fast speed over-current hybrid relay. 1 – module of adjusted reed relay; 2 – slave reed relay in ferromagnetic shield; 3 – high-voltage thyristor; 4 – varistor

Their distinctive features are high reliability (if standardized current and voltage limits are observed), fast response (fractions and units of milliseconds), excellent dust and moisture protection, no stripping and regulating during operation, small dimensions, full galvanic isolation of control circuit (coil) from output circuit (contacts), possibility to obtain high-voltage isolation between the control circuit and the output circuit with very simple means [53]. Another specific example of such hybrid protective relay is fast speed over-current relay which we designed especially for separating network automation, see Fig. 24 [54]. This device is very simple and contains a minimum number of elements selected with high voltage margin. Thus, for example the thyristor is designed for 1200 V and a miniature vacuum sealed switch is designed for 2000 V. Isolation between input coil and reed switch withstands voltages of 5 kV which can be increased if necessary. A suppressor can be added connected in-parallel to protecting varistor, as shown in Fig. 21.

As it follows from the above, recently new hazards have appeared that encourage continuing to use electromechanical protective relays resistant to powerful EMP. Conversely, new types of electromechanical relays capable of ensuring backup protection should be developed based on up-to-date technologies and materials.

Consequently, methods for improving MPD durability shouldn't include only technical innovations of the MPD structure. Organizational arrangements should include the stocking of printed board sets (modules) for MPD and proper storage. Since even disabled electronics can be damaged, such printed boards for MPDs should be stored in special well-shielded metal boxes. Modules of the central processor should be fully operational without

need of programming and set-up. Since it is not possible to provide spare printed board sets for all MPDs used in power systems for economic reasons, the most critical MPDs of the power system should be determined in advance in order to have enough spare boards. For MPDs having no spare boards, correct removal methods should be considered. Substations and electric stations should have complete and adjusted sets of protection panels based on electromechanical relays which can be rapidly put into operation in case of mass problems with MPDs.

In conclusion I'd like to note an oracular utterance of Winston Churchill who said many years ago, that *the latest refinements of science are linked with the cruelties of the Stone Age and to be amazed at his prophecy.*

REFERENCES

35. Gurevich V.I. Optoelectronic Transformers: Panacea or Specific Solution of Specific Problems? News of Power Industry, 2010, No.2, p. 24-28.
36. Gurevich V.I., Reliability of Microprocessor Relay Protection Devices: Myths and Reality. Problems of Power Industry, 2008, No. 5-6, p. 47-62.
37. Clark O. M., Gavender R. E. Lighting Protection for Microprocessor-based Electronic Systems. IEEE Transactions on Industry Applications, vol. 26, No. 5, 1990.
38. Bludov S.B., Gadetskiy N.P., Kravtsov K.A. et al., Generating Powerful Ultra-short Microwave Pulses and Impact on Electronics, Plasma Physics, 1994, vol. 20, No. 7, 8, p. 712-717.
39. Panov V.V., Sarkisian A.P., Several Aspects of Creation of Microwave Soft Kill Means, Foreign Radioelectronics, 1993, 10, 11, 12, p. 3-10.
40. Antipin V.V., Godovitsyn V.A., Gromov D.V., Kozhevnikov A.S., Ravayev A.A. Impact of Powerful Pulse Microwave Interferences on Semiconducting Devices and Chips, Foreign Radioelectronics, 1995, 1, p. 37-53.
41. Phadke A. G. Hidden failures in electric power systems. International Journal of Critical Infrastructures, vol. 1, No. 1, 2004.
42. Gurevich V.I. Electromagnetic Impact on MPD, Part 2. Components and Technologies, 2010, No. 3, p. 91-96.
43. Baydyn F.N., Nikitina V.N., Safronov N.B. Electrophysical Parameters and Radioshielding Properties of Magnesian-Shungite Composite Construction Materials. Reports of 9th Russian Scientific and Technical Conference on EMC of Technical Means and EM Safety, St. Petersburg, 2006, p. 292-294.
44. Gurevich V.I. The New Concept of MPD Design. Components and Technologies, 2010, No. 6, p. 12-15.
45. Schedrikov B.D. Eletromechanical Relay Protection Devices in Power Industry: Present and Future. Relay Protection and Automation, 2010, No. 1, p. 61-63.
46. Response of V.I. Gurevich to opponent protection engineers. News in Power Industry, 2009, No. 1, p. 41-42.
47. V.I. Gurevich, About Several Lines to Attack on the Problem of EMC of Relay Protection in Power Industry. Industrial Power Systems, 1996, No. 3, p. 25-27.
48. V.I. Gurevich, Principles of Improving Immunity of Static Current Relay. Power Industry and Electrification, 1992, No. 2, p. 16-18.
49. V.I. Gurevich, Improving EMC of Relay Protection in Power Industry. Industrial Power Systems, 1995, No. 2, p. 48-50.
50. V.I. Gurevich, About Development of Relay Protection in Electric Mains. Power Building, 1994, No. 1, p. 48-51.
51. V.I. Gurevich, New Generation of Universal Protection Relay of Maximal Current. Electrotechnics, 1994, No. 1, p. 61-66.
52. V.I. Gurevich, Hybrid Reed-Semiconducting Devices – New Generation of Protection Relay. Challenges of Power Industry, No. 9-10, 2007, p. 27-36.
53. Gurevich V. Protection Devices and Systems for High-Voltage Applications. – Marcel Dekker Inc., New York – Basel, 2003, 292 p.
54. V.I. Gurevich, High-Stable Fast-Speed Reed-Semiconducting Current Relay. Energo-Info, 2007, No.2, p. 84 - 88.

Received 18.03.2011

Gurevich Vladimir, Ph. D., Honorable Professor
Central Electrical Laboratory of Israel Electric Corp.
POB 10, Haifa 31000, Israel
e-mail: vladimir.gurevich@gmx.net

Gurevich V.I.

Stability of microprocessor relay protection and automation systems against intentional destructive electromagnetic impacts. Part 2.

Problems of impact of electromagnetic high-power pulses generated at nuclear explosion or by means of special equipment intended specially for damage of electronic equipment, in particular, digital protective relays and automatic systems, along with ways of protection against these impacts are considered.

Key words – **electronic equipment, relay protection, electromagnetic impacts.**