

8.



.3.

. - , -
 - (2) -
 , , -
 , .
 : 1. . . 1217493 , ⁴ B 07 B 4/00, . 10, 1986 .). 2. -
 64081 , 2004 ., . 2.

25.09.07

621.926

. . , . ,, . . , ,
 . , , . . , . ,, . . ,
 . . , ,
 . . , , . ,

We offered, made and patented structures for husk peeling and a small-size mill for grinding of free-flowing materials for farming.

(1).

(2).

(3).

(4).

(4),

().

, (. 1, 2)

2, 3, 1,

4,

5, 4

6. 5

7...8,
 7
 4,
 10
 4,
 11,
 12
 9
 13,
 14
 15
 10.
 16
 17,

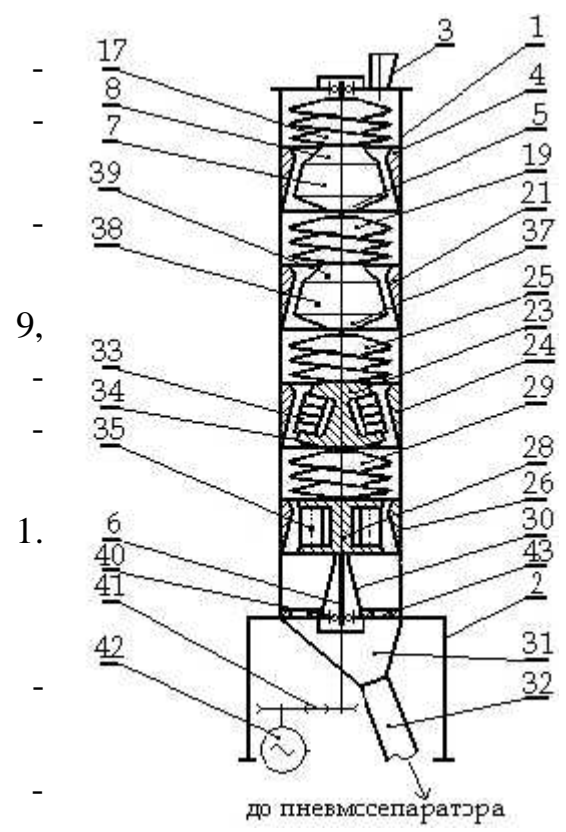

. 1.

16
 6
 18
 19,
 20.
 21
 () 23,
 6,
 18
 25.
 26
 27

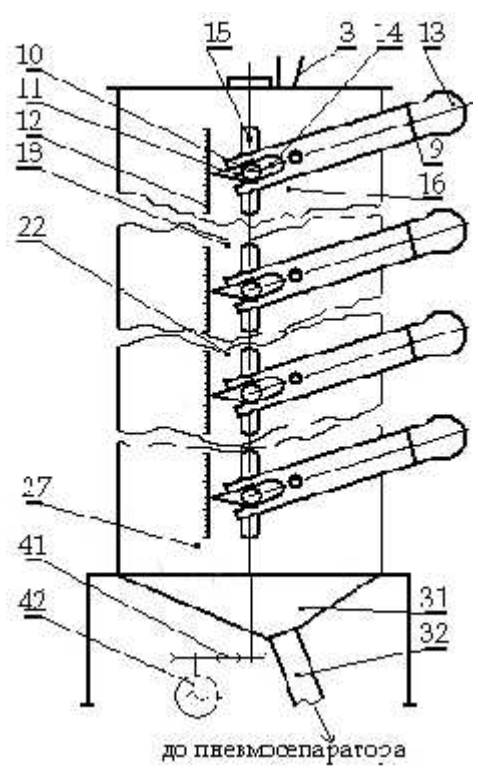

. 2.

37. 3 1, 7 8, -
17, 5, 4, 17 4 7, 8, -
, 19 1 -
18. 19 1 -
, 37, 38, 39 -
21. 4, 21. 25 1 -
22. 6 -
33, 34 -
23, 24 33. 27. 29 -
29 1 28 , -
, 35, 26. -
36, 26. -
, 1 -
30, 40, -
6, 41 42. -
43 31, -



.5.

. 5.

(5),

:1. RU 2129045 6 02 9/04, . 11, 20.04.99 . 2.
 28241 ,6 02 3/00, . 5-11 16.10.2000 . 3. . . 1641420, 5, B 02
 3/00, . 14, 15.04.91 . 4. 2014892, 5, B 02 15/08, . 12, 30.06.94 . 5. -
 2841 ,2000 . 6. 72369 ,2005 ., . 2

27.09.07

666.32/36

. . , . . , . . , . . ,
 . . , , “ ”

The results of kinetics research of ceramic bodies sintering on a granite breeds basis of central Priazovja are stated, the basic kinetic parameters, which characterize the mechanisms and causing intensity of materials sintering are determined. Is shown the utility of no conventional kinds of quartz - feldspar raw materials use for the reception of stoneware products with a complex of high operational properties.