

: 1.
 // . - 2004. - 3. - . 60-63. 2. . . , -
 . " . "
 . // . - 5. - 2002. - . 14-18. 3. . . , -
 . " . " // -
 . - 7. - 2006. - . 52-55. 4. . . . / . . , -
 . , . . | .n // « »: -
 2005. - 27. - . 51-56. 5. . . , . . , « » -
 . - 5. - 2000. - . 23-30. // -

04.08.07

621.927.8

. . , . " . . , ,
 . , . . , . " . . , ,
 . . , , . . , , ,
 . ,

We offered, made and patented a structure of pneumatic transport system for classification of free-flowing materials.

100

	,		-
	.	.	-
	,	,	-
	,	,	-
	.	.	-
			-
(1)			-
,	,	,	-
,	,	,	-
,	,	,	-
,	,	,	-
			-
			-
	,	,	-
	,	,	-
		.	-
			-
		,	-
2...3			-
90 %			-
			-
		.	-

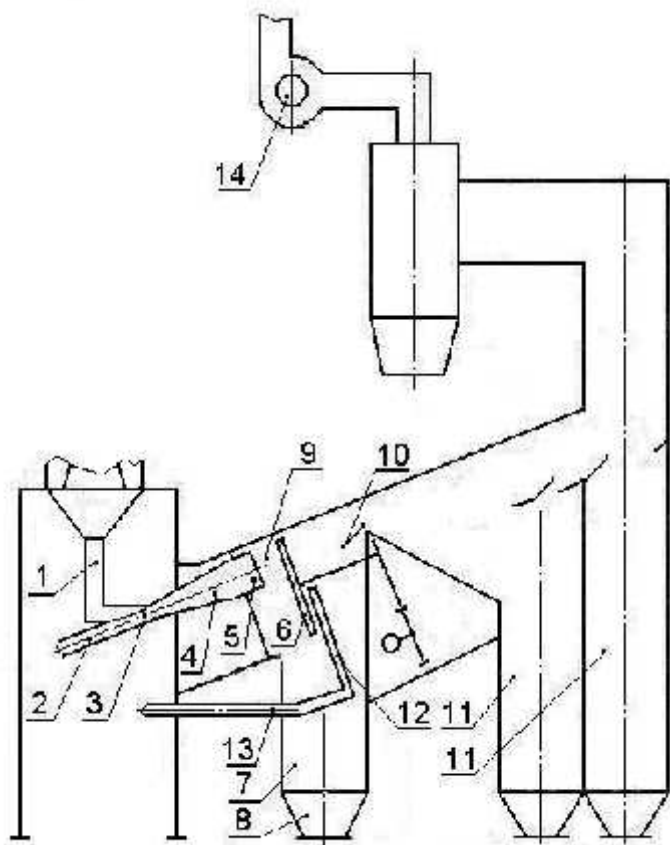

. 1.

- 13,
- 14
- 2,
- 1,
5
13

(. 1)
1,
2, 3,
, 4
5 ,
6,
7
8, 6
9 10
-
11
- ,
12,

(. 2, 3)



. 2.

(,
,
) ,
6,
-
7

8.



.3.

. - , -
 - (2) -
 , , -
 , .
 : 1. . . 1217493 , ⁴ B 07 B 4/00, . 10, 1986 .). 2. -
 64081 , 2004 ., . 2.

25.09.07

621.926

. . , . ,, . . , ,
 . , , . . , . ,, . . ,
 . . , ,
 . . , , . ,