

- 1.
- 2.
- 3.
- 4.

[2].

7-6

() ,

[2].

. 1.

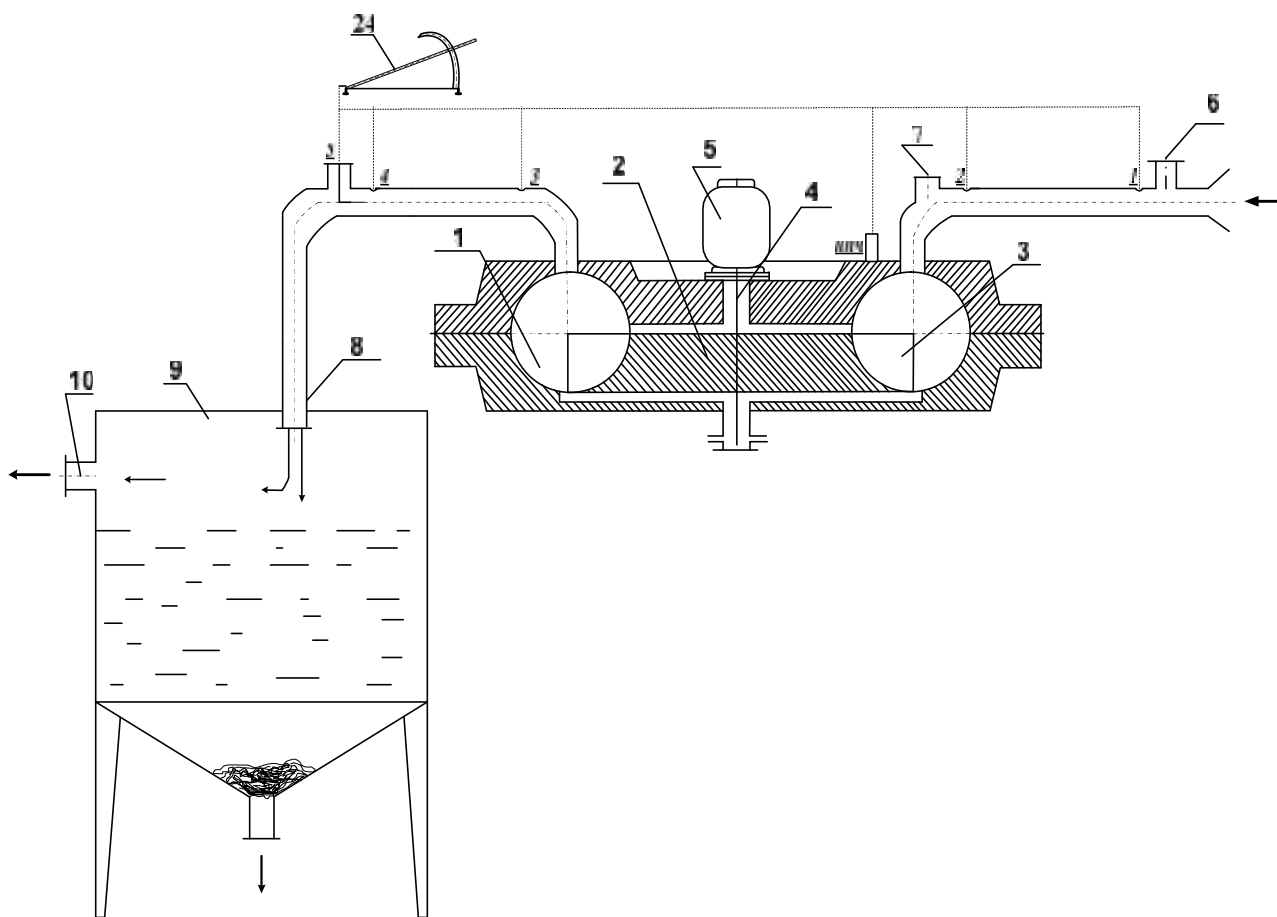

. 1.

1,

2

3.

4

5.

6

7

8

8,

9 [3 – 4].

[5 – 6].

11

.2,

.3.



.2.

11



.3.

(.4 – 6)

, ()
 ,
 ,
 0,3 0,6
 0,2 0,3 (.4).

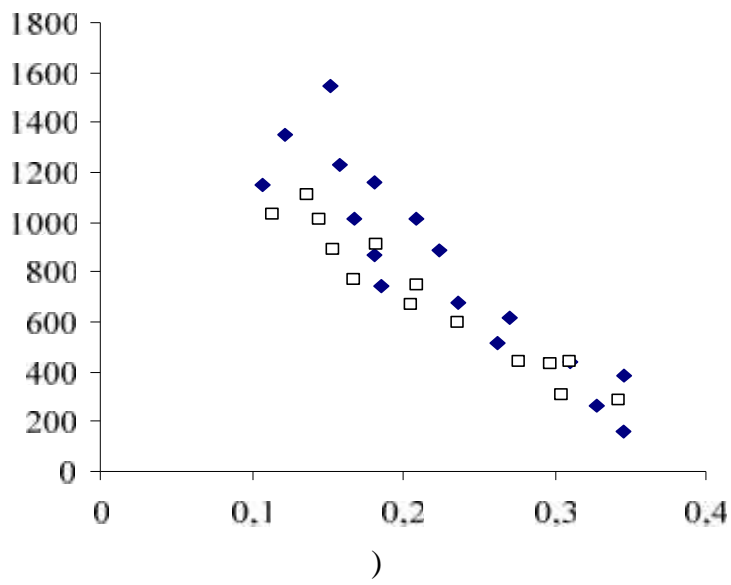
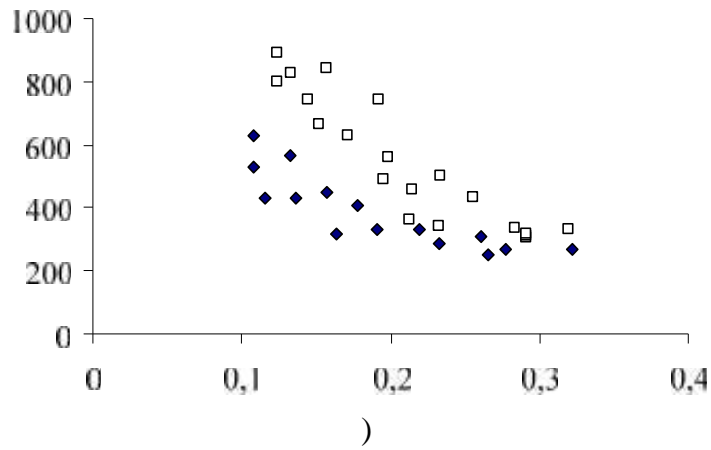

♦ – 11 ; □ – 11
 .4.
) ,)

[5 – 6].

(. 5).

= 0 [7].

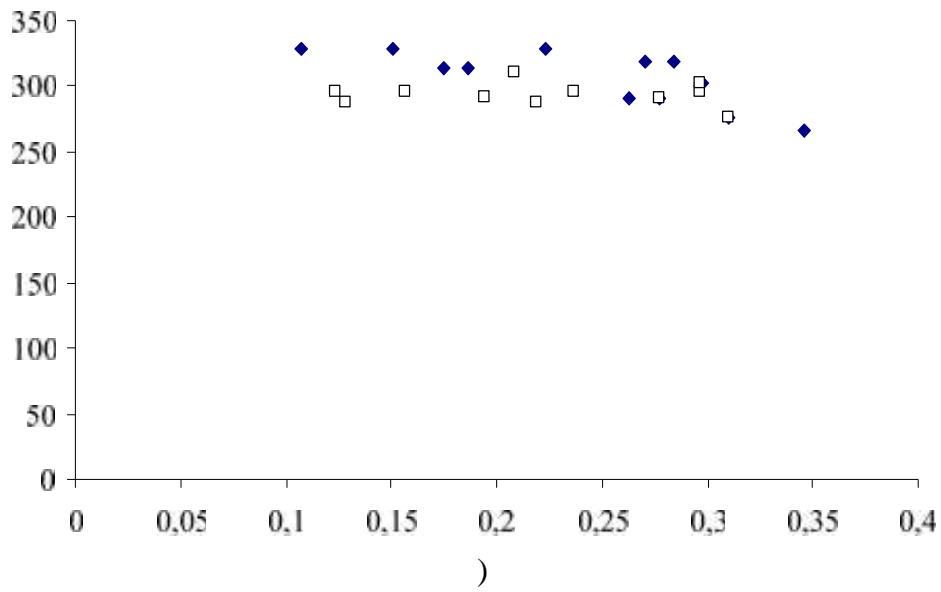
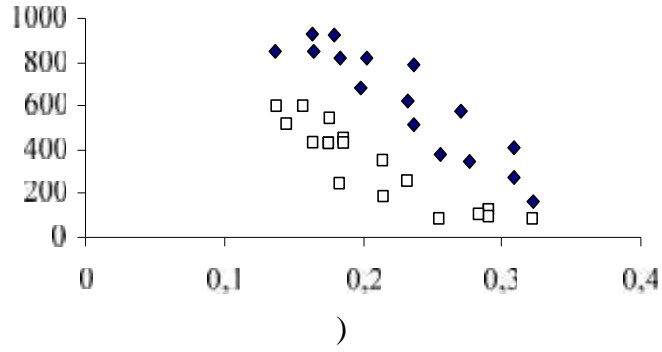

◆ — 11 ;
 □ — 11 .

.5.
)

(. 6)

[7].

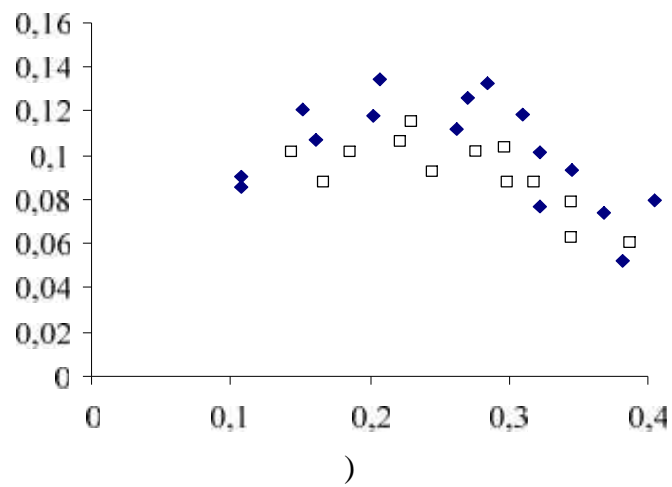
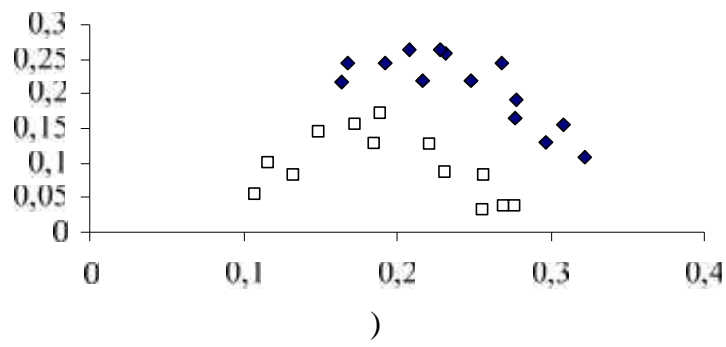

◆ – 11 ; □ – 11 .

.6. :

) ,)

1. , :

, ,

2. ,

: ,

3. ,

. : , , ,

4. , -

, ...

. -

5. -

- : 1. / . . . ,
- .: , 1968. – 392 . 2. 1604388, k . 01 D 3/30 3. -
- - .: , 1981. –197 . 4. -
- ” : -
- . . . -5. – ., 1978. – 51 . 5. . . .
- . - .: . , 1988. – 271 .
6. . . . ,
- . // « ».- : « », 2000. 7. -
- / . . . - .: , 1988. – 44 .
8. u 2007 08025 ().

23.10.07

666.762

. . . , . . . ,

. . . , . . . , “

” , . ,

. . . , . . . , « » , .

The results of phase compound and structure of MgO bush shybernyh flagstones for continuous bottling steel were researched there. This data for increasing chemical and thermal staunchness were recommended.

-

-

-

()

[1].