

53.083.92

....., « », , « », ,

ATmega8A.

(. 1).

P-CAD

(. 2).

Excel

$$y = 0.0055x^2 - 0.6178x + 20.579, \quad (1)$$

— , x — .

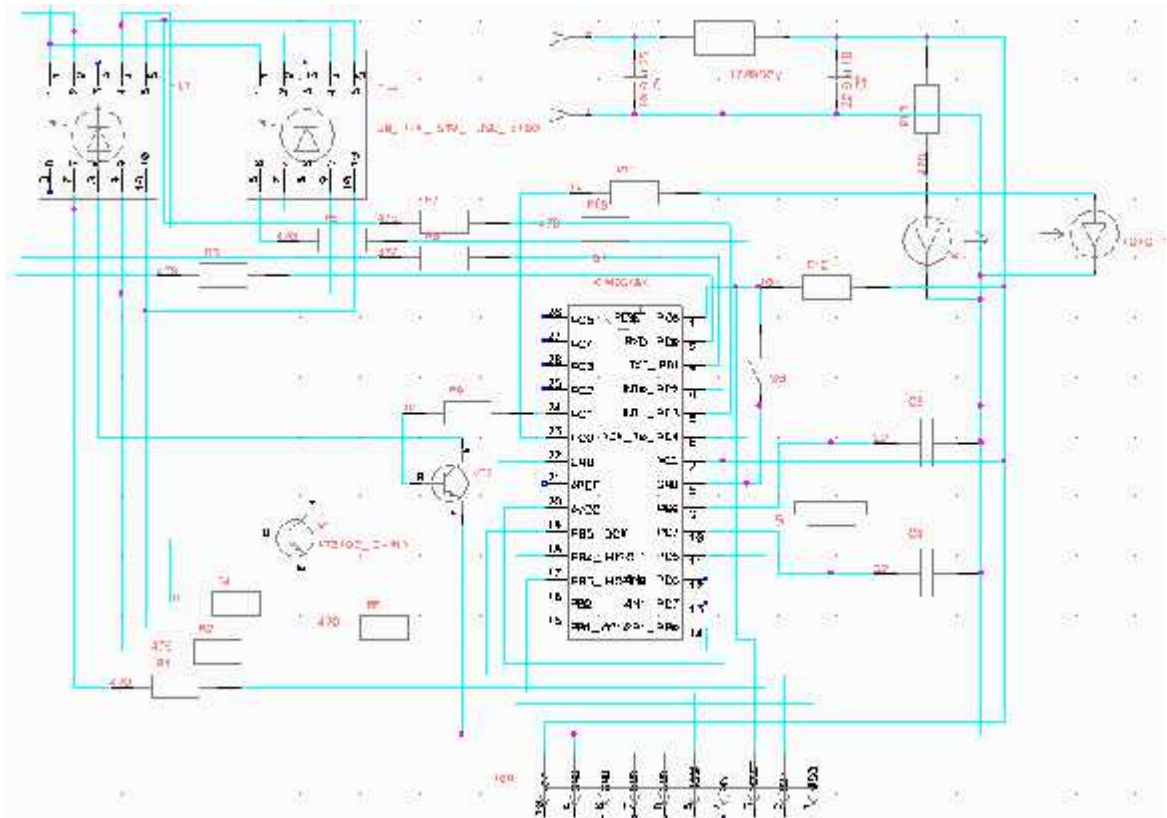

. 1 -

P-CAD

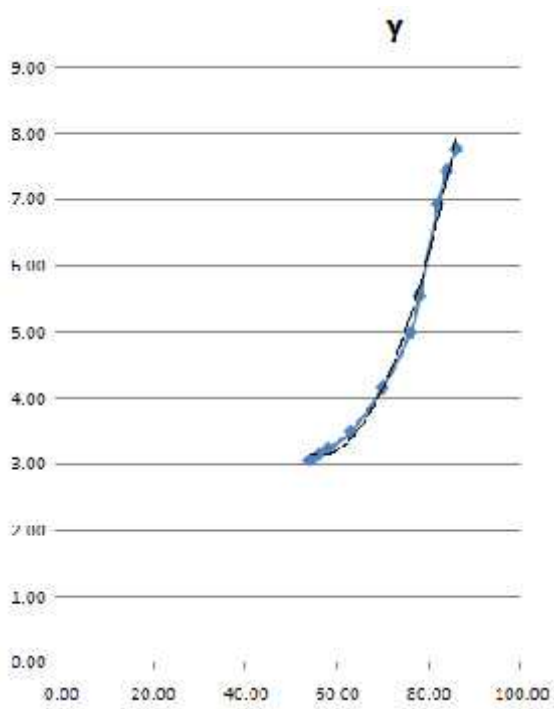

. 2 -

(1).

3 - 12 / .

1. , . . /

// . :

.- 1948. - 544 .

2. , . .

AVR / . .

// - : .

.- 2008. - 544 .